

The **rail-mounted switch SW-6CHL** (6 channel) is a cutting-edge product of the **MASTER Smart Home** line, suitable for controlling and managing (on-off) your lighting and electrical appliances. Installation of the SW-6CHL on the electrical panel enables on-off capabilities in 6 different sections of an electrical installation. Its high-definition liquid crystal display, the local and remote control of lighting or electrical appliances combined with information visualization make it unique. Automate, manage and control the state of your lighting and appliances in your home and business environment, operating locally via buttons and remotely over internet or Wi-Fi using smartphone, tablet or PC with the **MASTER Smart Home** app.

This user manual will help you install the MASTER Smart Home app for Android or iOS and enjoy the “smart” lighting control functions.

### Advantages

- Visualization, control and management of lighting and electrical appliances (on - off)
- User-friendly, easy-to-use interface
- Works with the Google Assistant voice commands
- Secure connection to Wi-Fi
- No hub/gateway is required
- Timer function
- Time-schedules
- Maximum economy and comfort with smart scenes
- Low implementation cost in existing or new installations

### Technical Specifications

<b>RAIL-MOUNTED SWITCH (6 MODULE)</b>	<b>6 Channel (Relay)</b>
SAFE OPERATING VOLTAGE	180 - 230V AC
SAFE OPERATING FREQUENCY	50Hz
OUTPUT POWER	1840W / 8A max per channel
OUTPUT POWER BOOST	The output power of the product can be extended by adding the corresponding power relay according of the electric load
STAND BY CONSUMPTION	≤ 1W
OPERATION TEMPERATURE	-20°C to +50°C
WIRE SIZE	∅ 0.5 mm to ∅ 3.5 mm
MOUNTING	Din-rail mounting 35x7.5mm (DIN 45277)
CONTROL	<u>Local:</u> - Instant push of product button - With one or more parallel connected buttons <u>Remote:</u> With the MASTER Smart Home app for smartphones or tablets over Wi-Fi or Data

**MASTER**  
Smart Home



RAIL-MOUNTED  
SWITCH  
6 CHANNEL

**SW-6CHL**



Works with  
Google Assistant  
voice commands



### Electrical Loads

R	L	C / L			
RESISTIVE	INDUCTIVE	CAPACITIVE / INDUCTIVE			
			Economy 	LED 	Filament 
2300W max	2300VA max	2300VA max	2300W max	2300W max	2300W max
1W min	1VA min	1VA min	1W min	1W min	1W min



This product complies with the requirements of the following EU Directives:  
2014/30/EE (EMC), 2014/35/EE (LVD)

*This product should be disposed of in accordance with national laws and environmental protection requirements*

### Draft of Electrical Installation

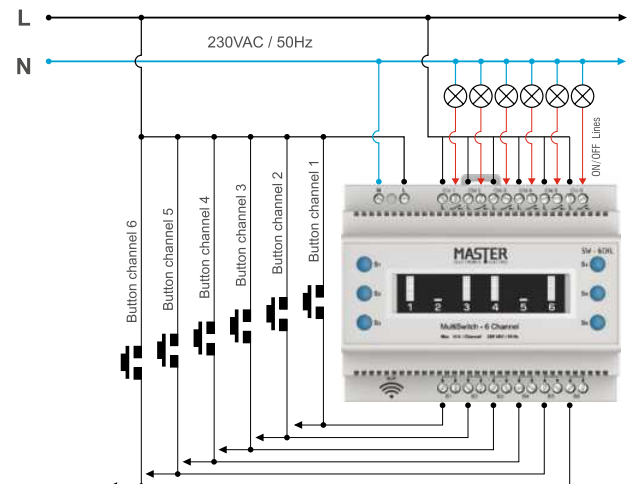

## Create a User Account

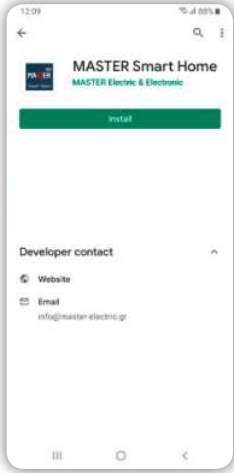

Step 1



Step 2

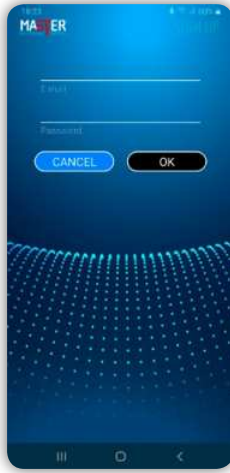

Step 3

Download the «MASTER Smart Home» free app and create an account.

### Step 1

Download the “MASTER Smart Home” application from Google Play or the App Store.

### Step 2

Launch the application and tap “SIGN UP”.

### Step 3

Enter your credentials, tap “OK” and follow the instructions in the activation email you received.

## Create a Location

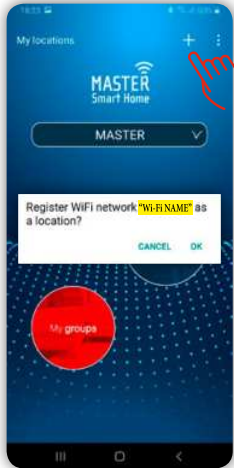

Step 4

Create easily and quickly different locations for the office or home.

\* First, make sure your Smartphone or Tablet is connected to your local Wi-Fi network..

### Step 4

Sign in to the “MASTER Smart Home” application and press “+” to create your location.

\* The name of the location that originally appears, is the name of your wireless local Wi-Fi network.

## New Device Connection



Step 5

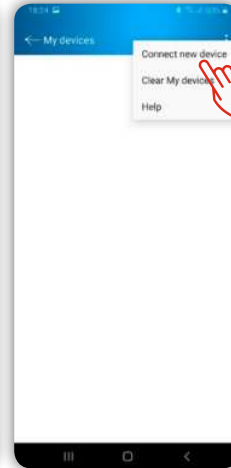

Step 6

Easily and quickly connect your smart device to your local Wi-Fi network.

### Step 5

From the app homepage, select “My Devices”.

### Step 6

Press “:” and select “Connect a new device” from the pop-up window.

## New Device Connection



Press the S1 S2 S3 control buttons on the SW-6CHL silmutaneously

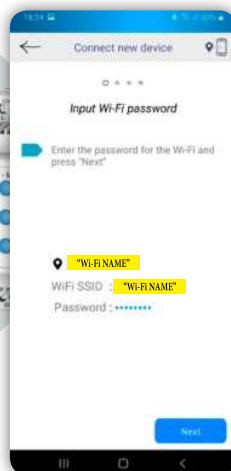

Step 7



Step 8

### Step 7

Press the S1 S2 S3 buttons on the SW-6CHL rail-mounted switch silmutaneously, and follow the instructions in the «MASTER Smart Home» application.

\* The “SSID” field automatically displays the name of your Wi-Fi network.

### Step 8

After its successful connection, the SW-6CHL rail-mounted switch appears in «My devices». Select the connected switch to operate or configure it.